

Communication device

CEEEOACH<sup>PLUS</sup>

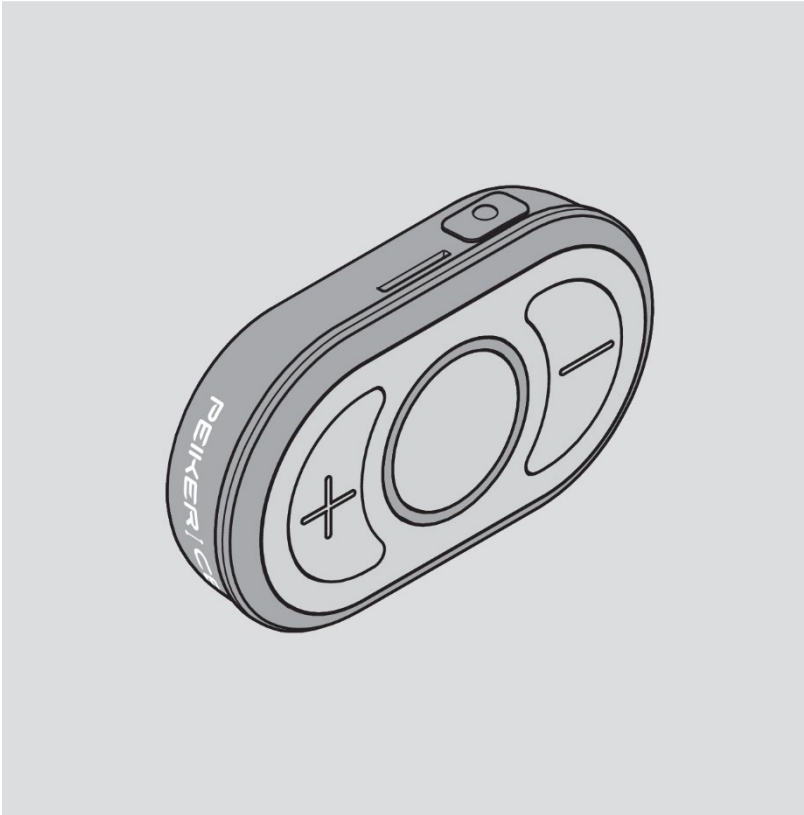

Instruction manual

English translation of the original instruction manual

01/2025

---

# Table of contents

<b>Notes on the instructions and the manufacturer .....</b>	<b>4</b>
<b>Keep guide available .....</b>	<b>4</b>
Information available online .....	4
Design features in the text .....	4
Copyright .....	5
Manufacturer address .....	5
<b>Security.....</b>	<b>6</b>
Intended use .....	6
Basic safety instructions .....	6
Avoid property damage and malfunctions .....	7
Design features of the warning labels .....	8
Design features of the notices on property damage .....	8
<b>Description .....</b>	<b>9</b>
Scope of delivery .....	9
Task and function .....	10
Controls.....	11
Indicators in the illuminated ring.....	12

---

<b>Unpack and check scope of delivery</b> .....	<b>13</b>
<b>Putting the device into operation</b> .....	<b>14</b>
<b>Switching the device on and off</b> .....	<b>15</b>
<b>Form group</b> .....	<b>16</b>
<b>Set volume</b> .....	<b>17</b>
<b>Switching the microphone on and off (mute function)</b> .....	<b>18</b>
<b>Key lock</b> .....	<b>19</b>
<b>Connect device with a Bluetooth® headset</b> .....	<b>20</b>
<b>Group Rejoin (Reunite Group)</b> .....	<b>22</b>
<b>Wear device on belt</b> .....	<b>23</b>
<b>Attach device to upper arm</b> .....	<b>25</b>
<b>Update the software of the device</b> .....	<b>26</b>
<b>Load device</b> .....	<b>27</b>
<b>Reset device to basic setting</b> .....	<b>29</b>
<b>Fix problem</b> .....	<b>30</b>
<b>Clean device</b> .....	<b>32</b>
<b>Storing and transporting the device</b> .....	<b>33</b>
<b>Dispose device</b> .....	<b>34</b>
<b>Technical data</b> .....	<b>35</b>
<b>Warranty statements</b> .....	<b>36</b>

---

<b>EU Declaration of Conformity .....</b>	<b>37</b>
<b>FCC Note .....</b>	<b>38</b>
<b>RF Radiation Exposure Statement .....</b>	<b>39</b>
<b>Canada, Industry Canada (IC) Notices .....</b>	<b>40</b>

---

## Notes on the instructions and the manufacturer

This manual will help you to use the CEECOACH<sup>PLUS</sup> communication device, version 1.2.2.x or higher, safely.

The CEECOACH<sup>PLUS</sup> communication device is referred to in the following as "device".

### Keep guide available

These instructions are part of the device.

- ▶ Make sure that this guide is always available for you.
- ▶ Always download the latest manual after an update.

### Information available online

Information about news regarding the function expansion and updates for the device can be found in the newsletter and on social media as well as at [www.peiker-cee.com](http://www.peiker-cee.com).

### Design features in the text

Normal text

- Enumeration
- ▶ Action steps

 Tips contain additional information.

---

## **Copyright**

This manual contains information that is subject to copyright. This manual may not be copied, printed, filmed, processed, duplicated or distributed in any form, either in whole or in part, without the prior written consent of peitel Communication GmbH.

©2024 peitel Communication GmbH

All rights reserved.

## **Manufacturer address**

pei tel Communications GmbH  
Rheinstraße 15 A  
14513 Teltow, Germany

Tel.: +49 3328 9363-0

E-mail: [info@peitel.com](mailto:info@peitel.com)

Internet: [www.peitel.com](http://www.peitel.com)

---

# Security

## Intended use

The device is used for group communication in sports and recreation. The device can communicate with a maximum of 16 participants in one group.

The range between the participants is up to m700.

The distance of the devices must be less than 10 m when connecting to a group.

Intended use also includes reading and understanding these instructions. Furthermore, you must observe and comply with all information in this manual, in particular the safety instructions.

Any other use is expressly considered improper.

## Basic safety instructions

### Avoid serious injury or death from explosions

The device does not have approval according to the ATEX directive for use in potentially explosive atmospheres.

- ▶ Only use the device in areas where there are no special requirements for explosion protection.

### Avoid risk of suffocation

Small parts are included in the scope of delivery. Children can swallow the small parts during play and choke on them.

- ▶ Make sure that the small parts do not get into the hands of children.

---

### **Avoid hearing damage**

Excessive volume can irreparably damage your hearing.

- ▶ Avoid continuous exposure to sound at maximum volume.

### **Avoid environmental damage**

- ▶ Dispose of the device and its components in accordance with the regulations applicable at the place of use.

### **Avoid property damage and malfunctions**

#### **Avoid damage to the device due to incorrect carrying**

- ▶ Attach the device to your belt or wear it securely on your upper arm. A belt clip or a wrist strap with Velcro closure are included.
- ▶ Do not drop the device.
- ▶ Avoid shock loads.

#### **Avoid headset cable breakage**

- ▶ To plug in or remove the cable, hold it by the plug only.

#### **Avoid damage to the device due to incorrect cleaning**

Cleaning with harsh cleaning agents can damage the device.

- ▶ Only use a soft cloth to clean the device if it is slightly dirty.
- ▶ Only use gentle cleaning agents for heavy soiling. Make sure that the cleaning agent does not affect the case parts and keys by testing it on a hidden spot.

#### **Avoid damage to the device due to improper repair**

- ▶ Never open the housing of the device.
- ▶ Have the device repaired by qualified personnel only.

---

## Design features of the warning labels

 <b>WARNING</b>	
	Notes with the word <b>WARNING</b> warn of a dangerous situation that can possibly lead to death or serious injury.

 <b>CAUTION</b>	
	Notes with the word <b>CAUTION</b> warn of a situation that may result in minor or moderate injury.

## Design features of the notices on property damage

<b><i>ATTENTION!</i></b>	
	These notes warn of a situation that will result in property damage and limited functionality.

# Description

## Scope of delivery

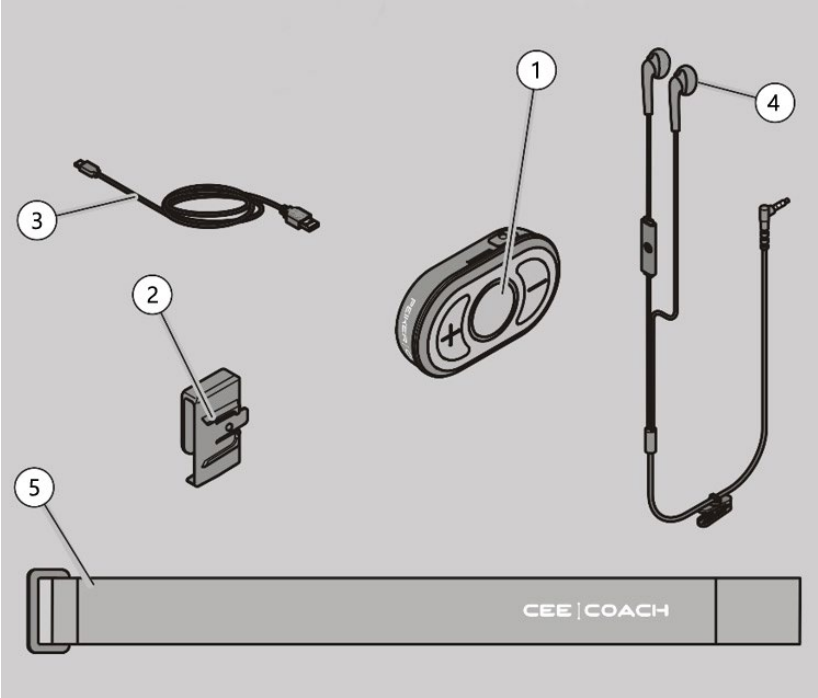

---

No.	Naming
1	Device (included in duo set 2 times)
2	Belt clip (included in duo set 2 times)
3	USB-C cable (included 2 times in the duo set)
4	Headset (included 2 times in the duo set)
5	Velcro tape (included in duo set 2 times)

### **Task and function**

The device is used for group communication in sports and recreation.

The device can communicate with a maximum of 16 participants in one group.

The range between the participants is up to m700.

The distance of the devices must be less than 10 m when connecting to a group.

**Controls**

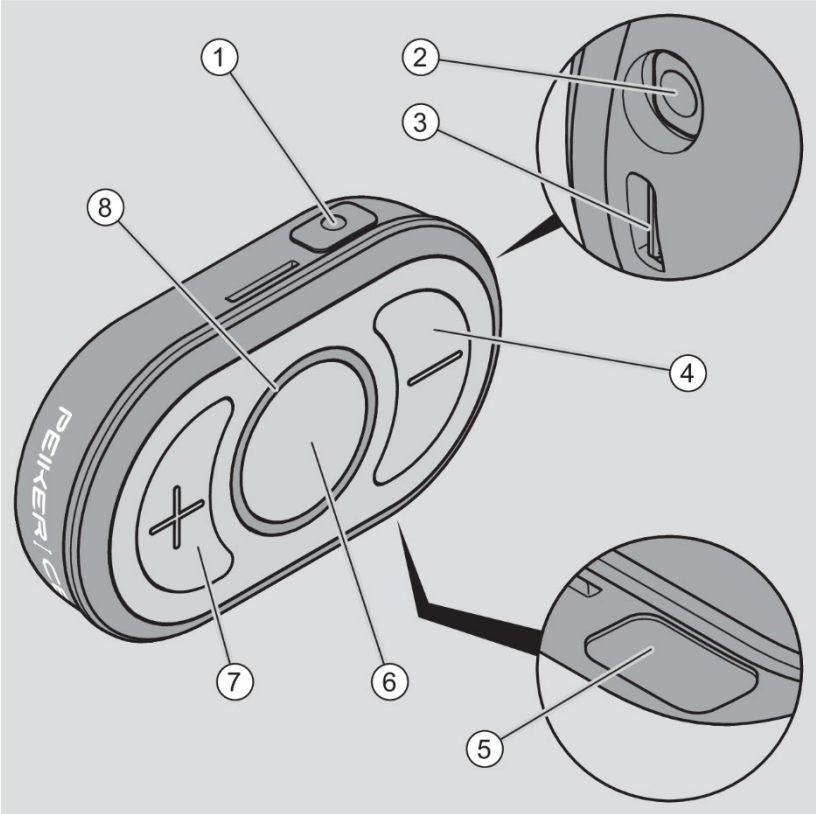



No.	Naming
1	Function key for connecting the device with other devices
2	Connection socket for headset
3	USB socket for USB-C cable
4	Minus key: Decrease volume
5	Function key for connecting the device with other devices or with the Bluetooth® headset.
6	Main key: <ul style="list-style-type: none"> <li>• Switch device on and off</li> <li>• Switch microphone on and off</li> </ul>
7	Plus key: Increase volume
8	Light ring

## Indicators in the illuminated ring

Color	Meaning
Red	Battery almost empty (less than 30% charged)
Yellow	Battery charged between 30% and 70%
Green	Battery more than 70 % charged Device is connected and at least one device is in transmit and receive range
White	There is no connection to other devices
Cyan	Device is connected, but there is no other device in the transmit and receive range
Blue	Device can be connected with a Bluetooth® headset
Magenta	The microphone is switched off

---

## Unpack and check scope of delivery

 <b>WARNING</b>	
	<p>Small parts are included in the delivery. Children can swallow the small parts during play and choke on them.</p> <ul style="list-style-type: none"><li>▶ Make sure that the small parts do not get into the hands of children.</li></ul>

- ▶ Remove the parts of the device from the original packaging.
- ▶ Keep the original packaging for possible return.
- ▶ Check if all parts of the device are included.
- ▶ Check the perfect condition of the parts.
- ▶ Contact the manufacturer if any parts are missing or damaged.

---

## Putting the device into operation

- ▶ Switch on the device (see the next section).
- ▶ Form a group with your team (page 15). You will only need this process the first time or if you want to create a new team.
- ▶ Use the headset as described in the manufacturer's instructions.
- ▶ When using a Bluetooth® headset, proceed as described in the section "Connecting the device to a Bluetooth® headset" starting on page 21.
- ▶ Connect the device to the desired other devices.

You can connect the device with up to 15 other devices to form a group (for this, see section "Forming a group" from page 16).

 The devices in the Duo Set are connected to each other in the delivery state.

---

## Switching the device on and off

- ▶ To switch on the device, press the main button (1) and hold it down for at least 3 seconds.

The illuminated ring (2) then shows a color (green, orange or red depending on the battery charge) for 3 seconds. You will also hear the voice prompt "Power on". As long as the device is switched on, an LED in the illuminated ring (2) flashes in the color

- White when the device is not connected to any other device.
  - Cyan if the device is connected to at least one other device, but it is out of range.
  - Green when the device is connected to at least one other device that is within range.
- ▶ To switch off the device, press the main button (1) again and hold it down for at least 3 seconds.

The illuminated ring (2) then shows a color (green, orange or red depending on the battery charge) for 3 seconds. You will also hear the voice prompt "Power off".

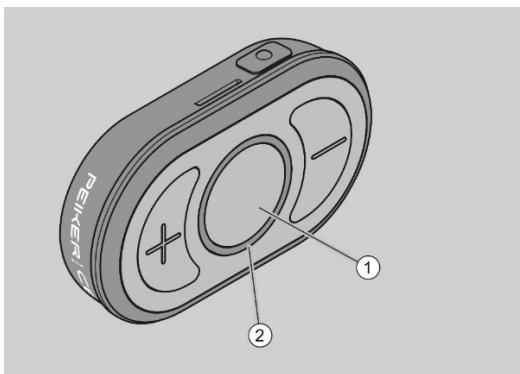

- ⓘ By default, the device is automatically switched off after five minutes if there is no connection to another device. This is the case when the LED lights up white (device is not paired) or cyan (no other device is within radio range) every 2 seconds.

---

## Form group

You can form a group with up to 15 other devices. The distance between the devices must be less than 10 m when connecting them.

- ▶ Make sure that the devices to be connected are within range.
- ▶ Switch on the devices (see "Switching the device on and off" from page 15).
- ▶ Press the function keys (1, 2) on the devices simultaneously for at least one second.

**i** From device to device, you have up to 10 seconds to press the function keys. After that, the group formation is completed. In the event that one or more devices have been forgotten, the group formation must be restarted with all devices.

The light ring fills up during the pairing time for all devices in the pairing state until pairing is complete. You will then hear the voice prompt "Device connected" when at least one other device has been successfully connected. The illuminated ring flashes green.

If no connection has been established, the illuminated ring flashes white.

- ▶ In this case, repeat the procedure.

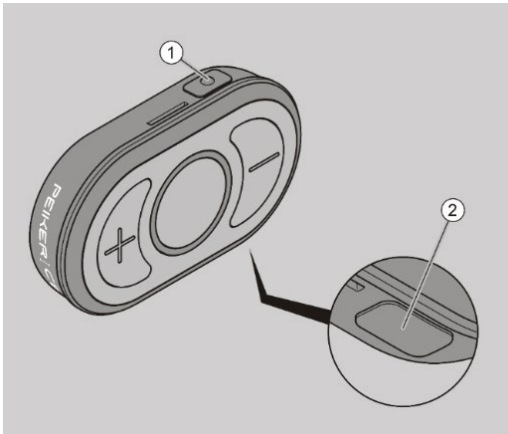

- 
- ❗ You can create new groups at any time by repeating the "Create group" operation.
  - ❗ The two devices in the Duo Set are connected to each other in the delivery state.

## Set volume

 <b>CAUTION</b>	
	Hearing damage possible due to excessively loud noises. ▶ Avoid continuous exposure to sound at maximum volume.

- ▶ To increase the volume, press the Plus button gradually.

The device becomes progressively louder. The ring fills up segment by segment. At maximum volume, the illuminated ring lights up completely.

- ▶ To reduce the volume, press the minus key step by step.

The device gradually becomes quieter. The ring empties segment by segment. At minimum volume, only one LED lights up.

- ▶ To quickly change the volume, press and hold the plus or minus button.

---

## Switching the microphone on and off (mute function)

► To switch off the microphone, press the main key (1) briefly.

You hear the voice prompt "Mute on". The light ring (2) flashes magenta. You will now no longer be heard by other connected subscribers.

► To switch on the microphone, briefly press the main button (1) again.

You hear the voice prompt "Mute off". You will now be heard again by the connected subscribers.

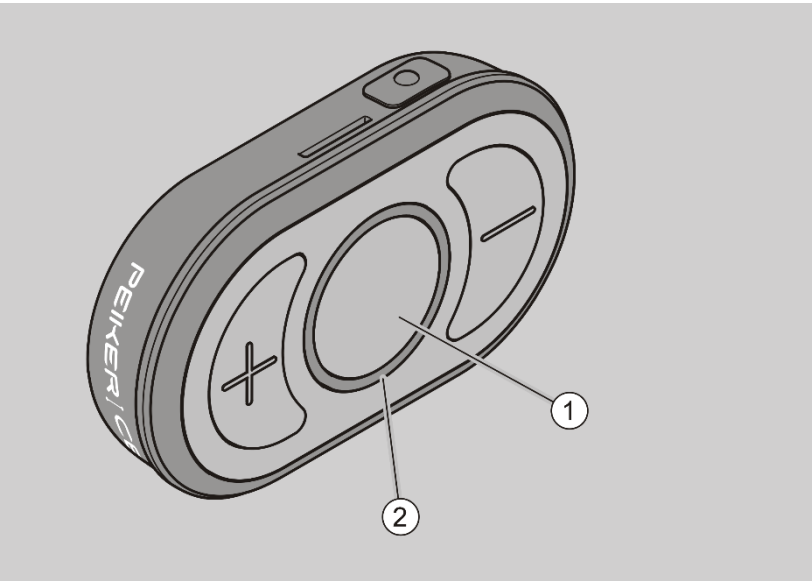

---

## Key lock

To prevent accidental pressing of a key, the device has a key lock.

- ▶ To activate the key lock, press the plus and minus keys simultaneously for 3 seconds.

The activation of the key lock is signaled to you by the illuminated ring. At 0, 3, 6 and 12 o'clock the LEDs flash and the color that corresponds to the connection status:

- White when the device is not connected to any other device.
- Cyan if the device is connected to at least one other device, but it is out of range.
- Green when the device is connected to at least one other device that is within range.

To deactivate an activated key lock, you have two options

- ▶ Press the Plus and Minus keys simultaneously for 3 seconds.

The successful deactivation of the key lock is signaled by the light ring, where only one LED flashes in the color corresponding to the connection status.

- ▶ Or switch off the device as described in the section "Switching the device on and off".

---

## Connect device with a Bluetooth® headset

- ▶ Switch on the device (see section "Switching the device on and off" from page 15).
- ▶ Turn on the Bluetooth® headset.
- ▶ Make sure that the Bluetooth® headset is in pairing mode. Follow the instructions in the Bluetooth® headset user manual.
- ▶ Press the function key (2) on the device.

The light ring glows blue in a circle. During this time, your device connects to the Bluetooth® headset.

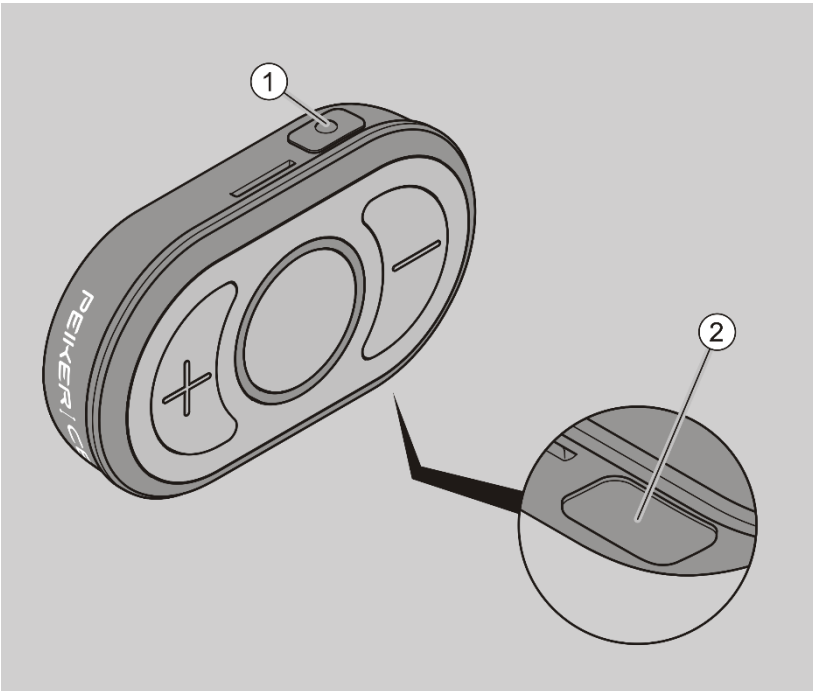

---

When using the device with a Bluetooth® headset, you need to keep the following in mind:

- If the device and the Bluetooth® headset are paired, they will automatically reconnect each time the device is turned on.
- If you want to connect the device to another Bluetooth® headset, you need to turn off the currently connected Bluetooth® headset. You can now connect the device to another Bluetooth® headset as described in this section.
- When a Bluetooth® headset is connected and a corded headset is plugged into the device, the connection transfers to the corded headset. As soon as the plug is pulled out of the connection socket, the audio connection automatically goes back to the Bluetooth® headset.

If the connection is not successful after switching on from a device with the Bluetooth® headset already paired, this could be due to the following reasons, for example:

- The battery of the Bluetooth® headset is discharged.
- The Bluetooth® headset is currently connected to another device, e.g. smartphone.

-  If the Bluetooth® headset is connected to another device, turn off the device so that the headset can connect to your device.  
If this procedure is exceptionally unsuccessful or no connection is established for some other reason, proceed as follows:
- ▶ Briefly press the function key (2) on the device.

---

## Group Rejoin (Reunite Group)

If members of your group get out of radio range, the rule for returning to the group's radio range is:

- If an individual participant loses the radio range of his group, he is automatically connected as soon as he is back in the radio range.
- If several participants lose the group, e.g. cyclists lose the connection to their group because one of them has a breakdown and one or more group members support him/her to fix it. In that case, these participants first form their own group.
- If the participants later find their way back to the overall group, an operator intervention, the so-called rejoin, is necessary to be accepted back into the group.
  - ▶ In this case, press the function key (1) on the device for at least 1 second to be included in the group again.



- If two participants have returned to the group, the second participant is automatically added to the group after one of them has performed the Rejoin function.
- If more than two participants return to a group, each participant must start the Rejoin function, again the last participant is automatically included.

Two groups that have never been paired before cannot connect via this function for security reasons. In this case, the "Form group" function must be executed as described on page 1. 5

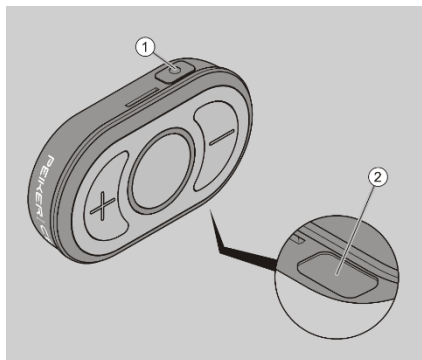

---

## Wear device on belt

### ***ATTENTION!***

Damage to the device possible due to incorrect carrying.

- ▶ If possible, attach the device to your belt with the included belt clip or wear it securely on your upper arm.
- ▶ Do not drop the device.
- ▶ Avoid shock loads.

- ▶ Attach the bracket to the device.
- ▶ Slide the belt clip (1) over the holder (2) until the locking lever audibly engages.
- ▶ Hook the device together with the belt clip (2.) on the belt (3).

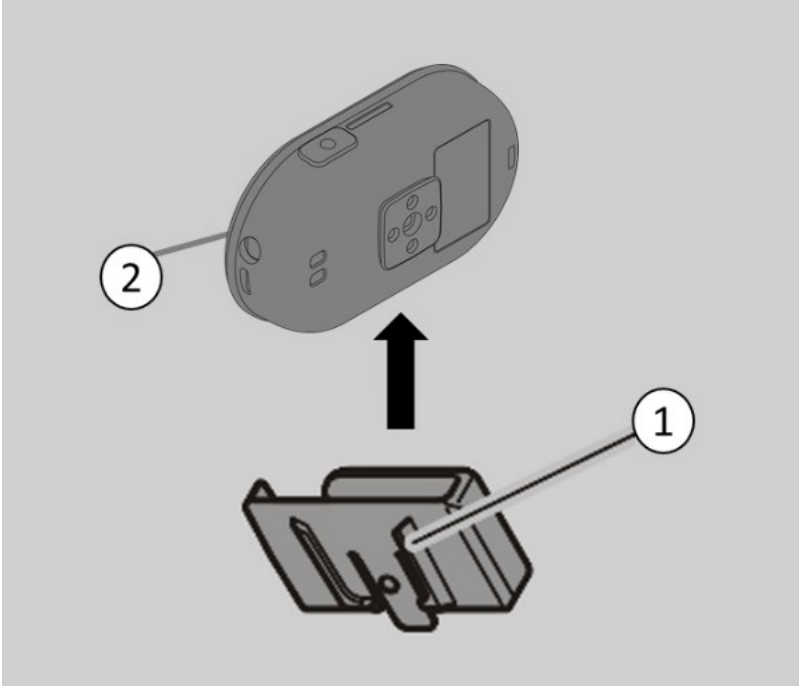

**i** Alternatively, you can thread the belt through the belt clip.

- ▶ To remove, lift the nose of the belt clip and pull the device together with the belt clip off the belt.
- ▶ To remove from the belt clip, pull the locking lever up and remove the belt clip from the device.

## Attach device to upper arm

- ▶ Slide the belt clip (1) over the holder (2) until the locking lever audibly clicks into place.
- ▶ Hook the device together with the belt clip (2) onto the wrist strap (3).
- ▶ To attach the device to your upper arm, pass the wrist strap (3) through the tab.
- ▶ Put your arm through the loop and attach the device to your upper arm with the wrist strap (3).

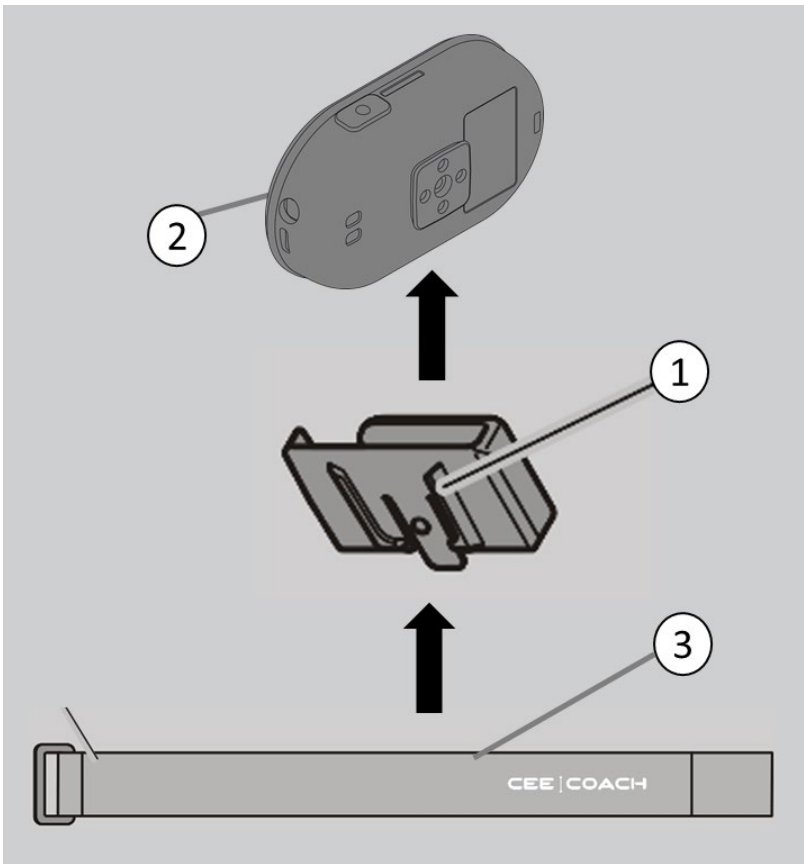

---

## Update the software of the device

An update app is available for Windows and Apple computers at [www.peiker-cee.com/support/software-updates/ceecoach-plus/](http://www.peiker-cee.com/support/software-updates/ceecoach-plus/) provided.

To download the update app you need a Windows (Windows 10) or an Apple computer (MAC-OS).

Alternatively, you can update your device wirelessly via the CEECOACH config<sup>PLUS</sup> app. See the next chapter

Proceed as follows:

- ▶ Download the updater file.
- ▶ After the loading process is complete, double-click the file to launch it. The update app will be installed.
- ▶ After launching the app, you will first be prompted to connect your device to your computer via the USB-C cable.

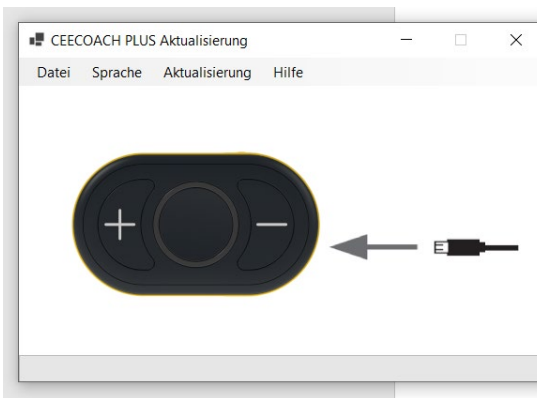

- ⓘ If you do not have administration rights on your computer, you will receive a corresponding message. In this case, log in as an administrator or call your IT administrator to install the update app.

## Load device

 <b>WARNING</b>	
	<p>Fire possible due to overheated components.</p> <ul style="list-style-type: none"><li>▶ Never charge the battery unattended.</li></ul>

- ▶ Insert the smaller plug of the USB-C cable (2) into the USB-C socket (1).

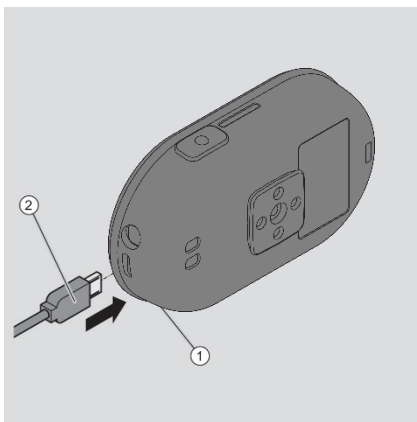

- ▶ Connect the larger plug of the USB-C cable to a charger.
- ▶ Connect the charger to a suitable power outlet.

The charging time depends on the ambient temperature and the power of the charger.

When the unit's battery is fully charged, the light ring will be solid green when the unit is turned off until the unit is disconnected from the charger.

---

You just want to check the charging status of your device.

- ▶ Switch the device on or off.

During this process, the charging status is displayed (for more information, see section "Indicators in the illuminated ring" from page 12).

---

## Reset device to basic setting

- ▶ Make sure that the device is turned on.
- ▶ Press the main button (1) and the plus and minus buttons simultaneously and hold them down for more than five seconds.

The illuminated ring (2) lights up green twice, white once and then orange. The device is switched off.

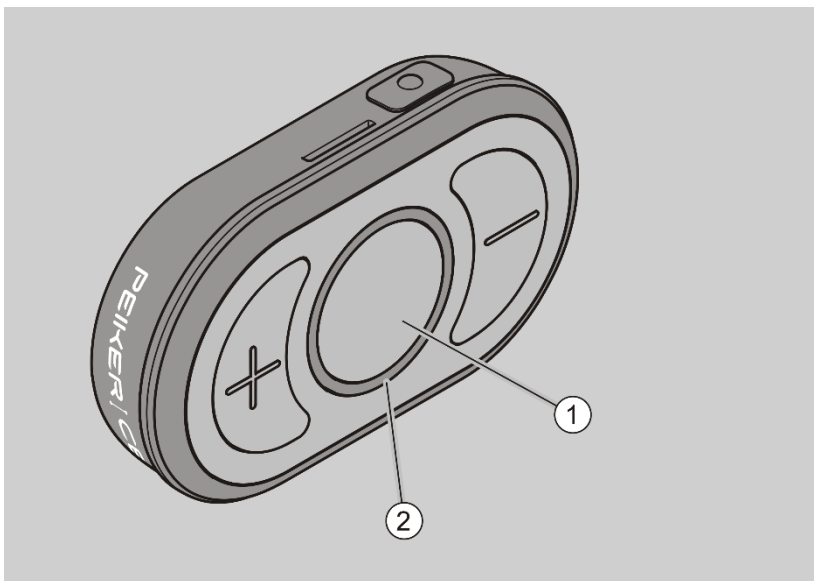

The following settings, among others, are deleted:

- existing connections to the other devices
- existing connection to the Bluetooth® headset.

---

## Fix problem

### **ATTENTION!**

Make sure that all devices in the group have the same software version. This is the only way to guarantee unrestricted use of all functions.

In the case of extensive function enhancements, we cannot guarantee communication between devices with different software versions.

<b>Problem</b>	<b>Possible cause</b>	<b>Remedy</b>
Device cannot be connected with the other devices to form a group.	<ul style="list-style-type: none"><li>• The other devices are out of range.</li><li>• You did not start the pairing process on all devices within 30 sec.</li></ul>	<ul style="list-style-type: none"><li>▶ Make sure that the devices are within the maximum distance of 10 m.</li><li>▶ Start the pairing process on all devices within 30 sec.</li></ul>

Communication does not work.	<ul style="list-style-type: none"> <li>• Microphone is switched off.</li> <li>• Participants are not in the - transmitting and receiving range.</li> </ul>	<ul style="list-style-type: none"> <li>▶ Make sure that the microphone is turned on.</li> <li>▶ Make sure that you are in the sending and receiving area.</li> </ul>
Device cannot be paired with the Bluetooth® headset.	<ul style="list-style-type: none"> <li>• The Bluetooth® headset does not allow pairing.</li> <li>• The Bluetooth® headset is not charged.</li> </ul>	<ul style="list-style-type: none"> <li>▶ Make sure that the Bluetooth® headset allows pairing.</li> <li>▶ Make sure that the Bluetooth® headset is charged.</li> <li>▶ Repeat the procedure according to section "Connecting the device to a Bluetooth® headset" from page 15.</li> </ul>
The speech in the Bluetooth® headset is disturbed.		<ul style="list-style-type: none"> <li>▶ Always wear the Bluetooth® headset on the same side of the body as the device</li> </ul>
At greater distances, there is interference with voice transmission		<ul style="list-style-type: none"> <li>▶ If possible, all group members wear the device on the same side of the body on the arm or belt</li> </ul>

**i** On the peiker CEE website you will find a list of frequently asked questions (FAQ), which is constantly updated. Check there as well to see if there is an answer to your problem.

---

## Clean device

### ***ATTENTION!***

Damage to the device possible due to the use of strong cleaning agents.

- ▶ Use only mild detergents for heavy soiling.

- ▶ Clean the device and the headset with a slightly damp cloth if necessary.
- ▶ Only clean the device with mild cleaning agents, e.g. dishwashing detergent, if it is heavily soiled.

---

## **Storing and transporting the device**

- ▶ Store the device and its components in a dry, dust-free place.
- ▶ For example, use the optionally available transport bag for storage and transport.

---

## Dispose device

At the end of its service life, the device and its components must be disposed of in an environmentally friendly manner.

- ▶ Dispose of the device in accordance with the regulations in force at the place of use.
- ▶ If in doubt, contact your city or local government.

The device consists of:

- Plastic housing
- Electronic components
- Batteries (Li-Ion)



## Technical data

Device	
Number of participants	2-16
Headset connector	Bluetooth® headset or standard 3.5 mm jack
Bracket	Clip can be snapped in 90° steps
Display	Light ring with 12 LEDs, multicolor
Number of keys	5
Device connection	USB-C
Charger connector	USB-A
Talk time (operating time)	up to 18 hours
Charging time / charging time	up to 3 hours
Power supply	Li-Ion battery, 2000 mAh
Ambient temperature for battery charging	+5° C to +45° C
Radio standards	Bluetooth®5.0 , HSP, HFP
Housing color	yellow/black - black/black
Key color	black
Operating temperature	-10° C to +45° C
Protection class	IP67 certification (splashproof, dustproof, shockproof)
Dimensions (W × H × D)	97 × 57 × 22 mm
Weight	96 g
Update	via USB
Certifications	CE (Europe), FCC (USA), ISED (Canada), ACMA (Australia)

---

## **Warranty statements**

pei tel Communications GmbH grants a manufacturer's warranty of two years from the date of purchase on all parts included in the scope of delivery within the scope of the statutory regulations (proof by proof of purchase). Improper handling or incorrect use exclude liability for defects.

---

## **EU Declaration of Conformity**

Hereby pei tel Communications GmbH declares that the device complies with the requirements and other relevant provisions of Directive RED 2014/53/EU.

For further information please visit: <https://www.peiker-cee.com/doc>

---

## **FCC Note**

This equipment has been tested and found to comply with the limits for a Class B digital device, pursuant to part 15 of the FCC Rules. These limits are designed to provide reasonable protection against harmful interference in a residential installation. This equipment generates, uses and can radiate radio frequency energy and, if not installed and used in accordance with the instructions, may cause harmful interference to radio communications. However, there is no guarantee that interference will not occur in a particular installation. If this equipment does cause harmful interference to radio or television reception, which can be determined by turning the equipment off and on, the user is encouraged to try to correct the interference by one or more of the following measures:

- Reorient or relocate the receiving antenna.
- Increase the separation between the equipment and receiver.
- Connect the equipment into an outlet on a circuit different from that to which the receiver is connected.
- Consult the dealer or an experienced radio / TV technician for help.

### **Note regarding FCC 15.21**

Warning: Changes or modifications not expressly approved by pei tel Communications GmbH void user's authority to operate equipment.

### **Note regarding FCC 15.19**

This device complies with Part 15 of the FCC Rules. Operation is subject to the following two conditions:

- (1) this device may not cause harmful interference, and
- (2) this device must accept any interference received,
- (3) including interference that may cause undesired operation.

---

## **RF Radiation Exposure Statement**

This equipment complies with the FCC/IC radiation exposure limits set fourth for portable transmitting devices operation in an uncontrolled environment. End users must follow the specific operating instructions to satisfy RF exposure compliance.

- This transmitter must not be co-located or operation in conjunction with any other antenna or transmitter.
- Any changes or modifications not expressly approved by the party responsible for compliance could void the user's authority to operate this equipment.

Model: CEECOACH <sup>PLUS</sup>  
FCC ID: 2ANUY-CEECPLUS

---

## Canada, Industry Canada (IC) Notices

This device complies with Industry Canada's licence-exempt RSS-102, RSS-247. Operation is subject to the following two conditions:

- (1) This device may not cause interference; and
- (2) This device must accept any interference, including interference that may cause undesired operation of the device.

L'émetteur/récepteur exempt de licence contenu dans le présent appareil est conforme aux CNR d'Innovation, Sciences et Développement économique Canada applicables aux appareils radio exempts de licence. L'exploitation est autorisée aux deux conditions suivantes :

- (1) L'appareil ne doit pas produire de brouillage;
- (2) L'appareil doit accepter tout brouillage radioélectrique subi, même si le brouillage est susceptible d'en compromettre le fonctionnement.

Model: CEECOACH <sup>PLUS</sup>

IC: 23265-CEECPLUS

M/N: CEECOACH PLUS